



ALSONIC-SAVM

Open Channel Area-Velocity Flowmeter

ALSONIC SAVM Series

GENERAL

SMARTMEASUREMENT's **ALSONIC SAVM** system is multi-path transit time area-velocity flow meter designed for partially filled sewer pipes. The Alsonic-SAVM operates with an external level transmitter which measures the changing liquid level in the open sewer pipe to determine the area portion of the flow equation which is then multiplied by the velocity measurement from the transducer array in order to calculate the instantaneous flow rate. The ALSONIC-SAVM consists of an advanced DSP-based flow computer with three paths for sewer pipes of 6-10" (150-250mm) and four transducer paths for pipes ranging from 12" (300mm) to 32" (800mm). Velocity measurement is determined via the transit time difference of ultrasonic sound pulses method. Ultrasonic pulses are transmitted upstream and downstream across the channel at an angle α between the flow direction and the sonic wave path, with the difference in the sonic wave's transit times being directly proportional to the liquid velocity. The ALSONIC-SAVM fits snugly inside a round sewer pipe of up to 32" (800mm) in diameter with a level transmitter placed on top of an opening in the sewer pipe. Since the transducers create almost no restriction, virtually no head loss is created. The advanced DSP-based flow computer with cross-correlation and FFT technology allows this system to work in the most difficult applications, including those involving liquids with high concentrations of suspended solids & air of up to 30% or in environments having large noise component. Request a quote on an ALSONIC-SAVM sewer area velocity ultrasonic flow meter for your application. Contact SmartMeasurement to learn more.



FEATURES

- Color graphic LCD display: 128x64 for flow rate, total flow & signal shape
- Designed for very low flows occurring during overnight hours and full pipes during rainy seasons.
- No-moving-parts design creates no pressure loss
- Designed to eliminate errors due to sand and sedimentation
- Alarms for excess sludge deposits
- Velocities from 0.03 ~ 40 feet/sec (0.05 ~ ± 12 m/s)
- High open-channel accuracy; ±1.0% of reading
- Oscilloscope function for diagnostics
- Data logger function; includes date, totalizer, diagnostics
- Response time less than 1 second



SPECIFICATIONS

• Measuring Principle:	Ultrasonic transit-time differential, 3 or 4-path	• Data logger:	32 Mbytes; up to 200,000 records
• Max pass length:	32" (800 mm)	• Weight:	See data sheet
• Channel Geometrics:	Cylindrical sewer & drainage pipes	• Power Supply::	90~250 VAC, 50/60 Hz,
• Velocity Range:	±0.03~40 feet/sec (±0.01~12m/s)	• Outputs:	4-20 mA DC, relay, RS-232C/485
• Accuracy:	±1.0% of reading	• Communication:	MODBUS RTU 485/RS-485
• Flow Rate:	4½ digit	• Input:	4-20 mA DC/Pulse
• Repeatability:	±0.5% of reading	• Max cable length:	650' (200m)
• Engineering Units:	m ³ , Liter, US Gallon, Imperial Gallon, Thousand Gallon, Cubic Feet, US Barrels, Imperial Barrels, Oil Barrel	• Alarm:	Two relays for total/hi flow
• Totalizer:	10-digit, Positive, Negative & Net values	• Data storage:	EPROM storage up to 10 years
• Turn down ratio:	1000:1	• Power Consumption:	Less than 20 W
• Response Time:	Less than one second	• Dimensions:	See data sheet
• Keypad:	16 key	• Enclosure Mounting:	Wall mount
• Ambient temperature:	-4~140°F (-20~60°C)	• Transducer Materials:	Ultem®
• Resolution:	0.003 feet/sec (0.001 m/s)	• Protection (converter):	NEMA 4 (IP 65)
		• Protection (transducers):	NEMA 6P (IP68) – Submersible

APPLICATIONS



INSTALLATION

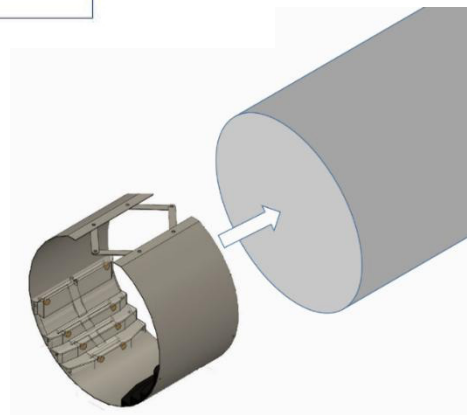
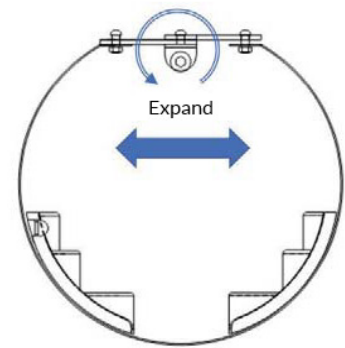
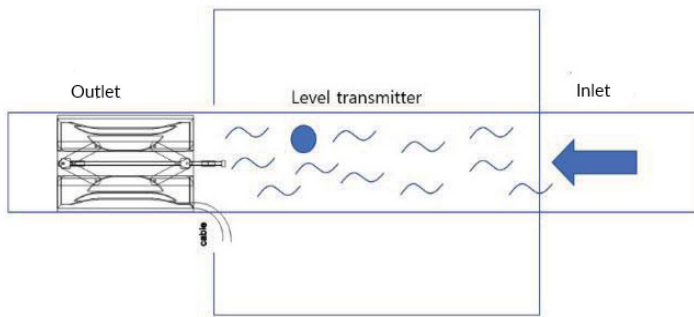

Low Level Flow

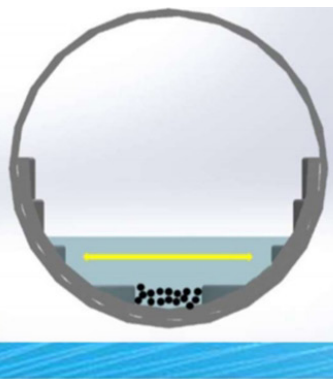

Deposit Alarm

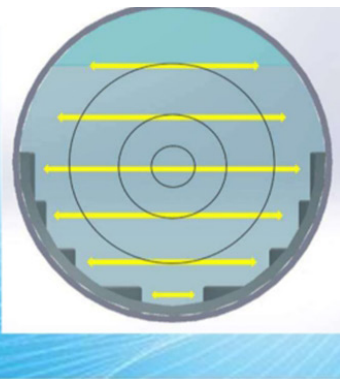

Full Pipe Flow

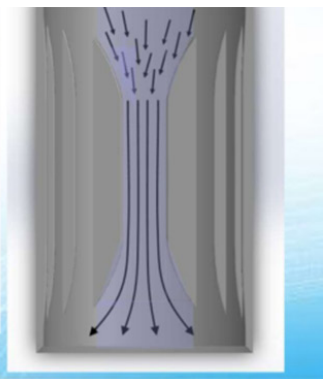

Patented Design

■ Digital Processing Technology: Cross Correlation, Transit-Time

■ Key Benefits:

- Possible to measure low flows
- Possible to measure large flows occurring during rainy season
- Alarm for path 1 solid/sediment build-ups
- Sensor geometry increases fluid velocity

■ Oscilloscope diagnostic function

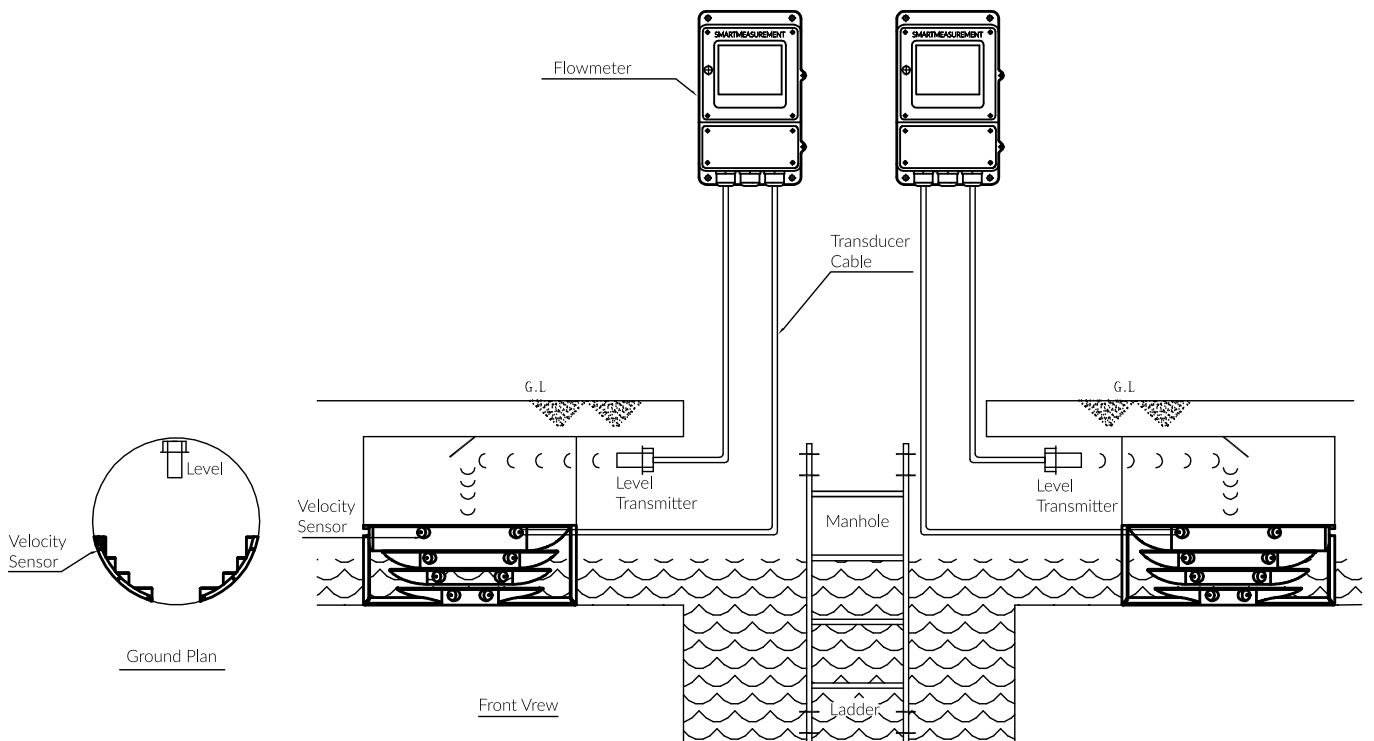
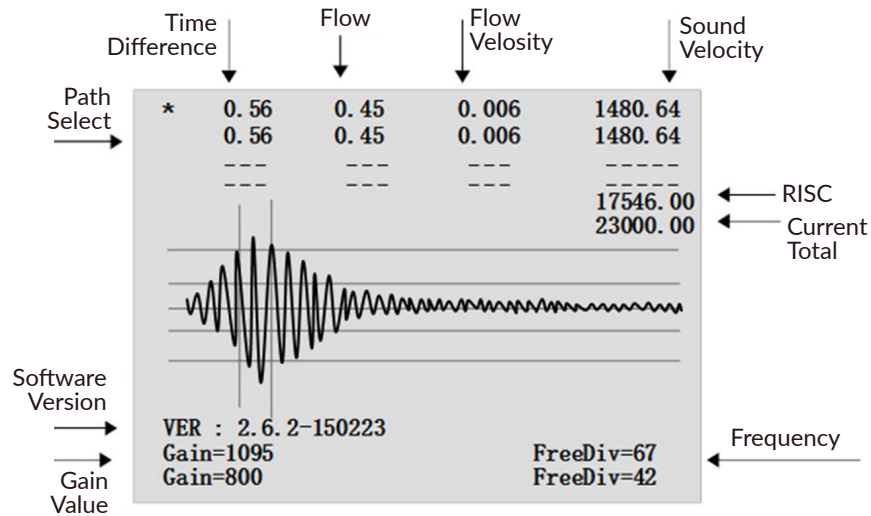

Please contact your **SmartMeasurement** application engineer
 You also need to provide the following information:

TYPE OF FLUID	Please provide the name of your fluid, including operating density and viscosity
LINE SIZE	Please indicate nominal pipe diameter
PROCESS PRESSURE AND TEMPERATURE	We will calibrate your flowmeter as close to your operating conditions as possible
TYPE OF ELECTRONICS	Please specify output and installation type
PIPE NAME AND MATERIAL	Please provide liquid level range. The min level and the max level.
PIPE CONDITION	Straight pipe condition (10D upstream, 5D downstream of sensor location) required

ALSONIC-SAVM					
EXAMPLE 1: ALSONIC-SAVM-100MO-LD(#)- (200MM)-C10					
ALSONIC-SAVM-	**	**	**	**	DESCRIPTION
NEMA 4 with keyboard, up to 4 path/channel	100LO	Sewer ID	# paths		Flow meter
LO-150 6" (150mm)		3 paths			Transducer
LO-200-250 8"~ 10" (200-250mm)		3 paths			
LO-300-350 12"~14" (300-350mm)		4 paths			
LO-400-450 16"~18" (400-450mm)		4 paths			
LO-500-600 20"~24" (500-600mm)		4 paths			
LO-700-900 28"~36" (700-900mm)		4 paths			
LO-900-1200 36"~48" (900-1200mm)		4 paths			
Cable length (standard is 10 m)			Cxx		Extra Cable

