



# ALBRPD

## Positive Displacement Flowmeters

### Series ALBRPD Meters

## GENERAL

SMARTMEASUREMENT's Bi-Rotor Positive Displacement flowmeter (ALBRPD) features two precisely machined rotating members known as helical rotors which rotate and mesh within the meter's interior housing in order to form a measuring chamber of known volume which may be used to accurately determine volumetric flow rate as a function of the rotors' velocity. The helical rotors' motion is transmitted to the display via a sealed coupling & drive system that enables the display to provide accurate data for both flow rate and total accumulated flow. The unique helical rotor design provides a number of advantages over traditional gear-type PD meters including reduced pressure drop, the virtual elimination of down-stream pulsations, enhanced particle tolerance, and reduced maintenance. The advantages provided by the helical rotor make the ALBRPD an ideal choice for many applications including oil-in-water media and fluids with small entrained solids.



Bi - Rotator



Flow In

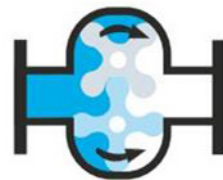

Measuring



Measuring

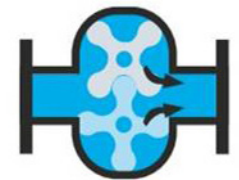

Flow Out

## FEATURES

- Superior accuracy of up to 0.1% of reading (0.5 % standard)
- Uniform rotation means low pressure loss
- No metal-to-metal contact provides for long service lifetime
- Self-lubricating
- Very low noise and vibration
- Reduced number of parts reduces maintenance requirements
- Rugged double case construction prevents loss of calibration due to changes in pressure or temperature
- NIST traceable calibration certificate



Vertical - electronic transmitter



Vertical - SS



Vertical - mechanical register



Horizontal

## SPECIFICATIONS

- Flow range: up to 8800 US GPM (2000 m<sup>3</sup>/hr)
- Line size: ¼" ~ 16" (8 ~ 400mm)
- Operating pressure: max. 930 psig (64 bar)
- Process temperature: -22 ~ +480 °F (-30° ~ +250°C)
- Body Material: std - CS, opt - SS# 304, SS# 316
- Viscosity: up to 20,000 cP
- Enclosure rating: NEMA 4 (IP 65)
- Working Temperature: +104 ~ +176 °F (+40° ~ +80°C)
- Working Humidity: <90% @ +75 °F (+22°C)
- Accuracy: std ±0.5%RD, opt ±0.2%RD, ±0.1%RD
- Repeatability: <90% @ 75 °F
- Pulse Output: (24V<sub>DC</sub> ±5%, V<sub>H</sub> ≥20V, V<sub>L</sub> <1V and output load <200Ω)
- Current Output: 4 ~ 20mA, (two wire system w/ 600Ω max loop load)
- Digital output: RS485/RS232 communication with Modbus RTU (powered by 24V<sub>DC</sub> ±5% and <60mA)
- Display: rate, total
- User parameters: K-factors, linear correction coefficient, flowrate input signal section points, pulse output range, decimal precision.

## ■ Typical Performance Basic Error and Pressure Loss (%)

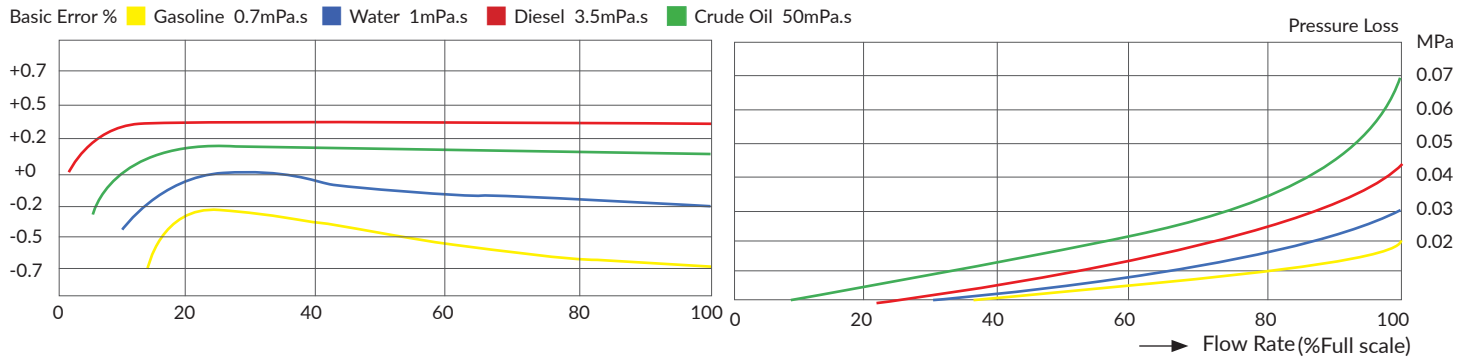

## ■ Carbon Steel, Accuracy: 0.5% and 0.2%, -20~+150 deg°C

Size (mm)	Flow range (m <sup>3</sup> /hr)												Pulse equivalent liter/pulse
	0.32~0.8 cP		0.8~2 cP		2~5 cP		5~400 cP		400~2k cP		2k~20k cP		
	Gasoline		Kerosene		Light diesel		Crude oil		Hi~viscosity Liquid		Super~high viscosity		
	0.50%	0.20%	0.50%	0.20%	0.50%	0.20%	0.50%	0.20%	0.50%	0.20%	0.50%	0.20%	
½" (15)	0.6~3		0.4~4		0.4~4		0.4~4		0.3~2.4		0.3~2.4		0.001
1" (25)	3~8		1.5~10		1~10		1~10		1~8		1~6		0.01
1½" (40)	8~20	8~20	2.7~22	5.5~22	2.5~25	4.4~22	2.5~25	4.4~22	2.1~18	4.2~18	1.5~12	3~12	
2" (50)	9~36	15~36	4.5~36	9~36	4~40	7.2~36	4~40	7.2~36	2.8~24	6~24	2.2~18	4.5~18	0.1
3" (80)	20~80	32~80	10~80	20~80	9~90	16~80	9~90	16~80	6.5~56	14~56	5~40	10~40	
4" (100)	25~100	40~100	13~100	25~100	12~120	20~100	12~120	20~100	8.5~72	18~72	6.5~54	14~54	
6" (150)	55~225	88~220	31~250	57~225	25~250	44~220	25~250	44~220	18~150	38~150	12~100	25~100	
8" (200)	90~360	150~360	50~400	90~360	40~400	72~360	40~400	72~360	28~240	53~210	20~160	40~160	
10" (250)	135~540	180~540	68~540	135~540	60~600	108~540	60~600	108~540	42~360	90~360	30~240	60~240	
12" (300)	220~900	300~900	112~900	225~900	100~1000	180~900	100~1000	180~900	70~600	150~600	54~450	113~450	
14" (400)	400~1600	550~1600	200~1600	400~1600	180~1800	320~1600	180~1800	320~1600	130~1100	275~1100	90~750	180~750	

## ■ Small Size, Electronic Counter, Accuracy: 0.5%, 0.2%

Size (mm)	Flow range (m <sup>3</sup> /hr)												Pulse equivalent liter/pulse
	0.32~0.8 cP		0.8~2 cP		2~5 cP		5~400 cP		400~2000 cP		2000~20000 cP		
	Gasoline/liquefied gas		Kerosene		Light diesel		Crude oil, heavy oil		Hi~viscosity Liquid		Liquid with high water content & super~high viscosity liquid		
	0.50%	0.20%	0.50%	0.20%	0.50%	0.20%	0.50%	0.20%	0.50%	0.20%	0.50%	0.20%	
¼" (8)	0.06~0.3	0.10~0.3	0.05~0.3	0.07~0.3	0.03~0.3	0.06~0.3	0.03~0.3	0.06~0.3	0.03~0.27	0.06~0.27	0.03~0.24	0.06~0.24	0.01
½" (15A)	0.2~0.8	0.27~0.8	0.1~0.8	0.2~0.8	0.08~0.8	0.16~0.8	0.08~0.8	0.16~0.8	0.08~0.7	0.16~0.7	0.08~0.6	0.15~0.6	
½" (15B)	0.25~1	0.33~1	0.2~1	0.25~1	0.1~1	0.2~1	0.1~1	0.2~1	0.1~0.9	0.2~0.9	0.1~0.8	0.2~0.8	
1" (25)	1.5~6	2~6	1.2~6	1.5~6	0.6~10	1.2~10	0.6~10	1.2~10	0.6~6	1.2~6	0.6~5	1.2~5	0.1

- \* NOTE: 1. Please consult factory for high temperature/pressure/accuracy.  
 2. Consult factory for oversize / undersize flange connections.  
 3. 0.1% accuracy available - please contact factory for flow rates.

### Vertical mount with standard transmitter

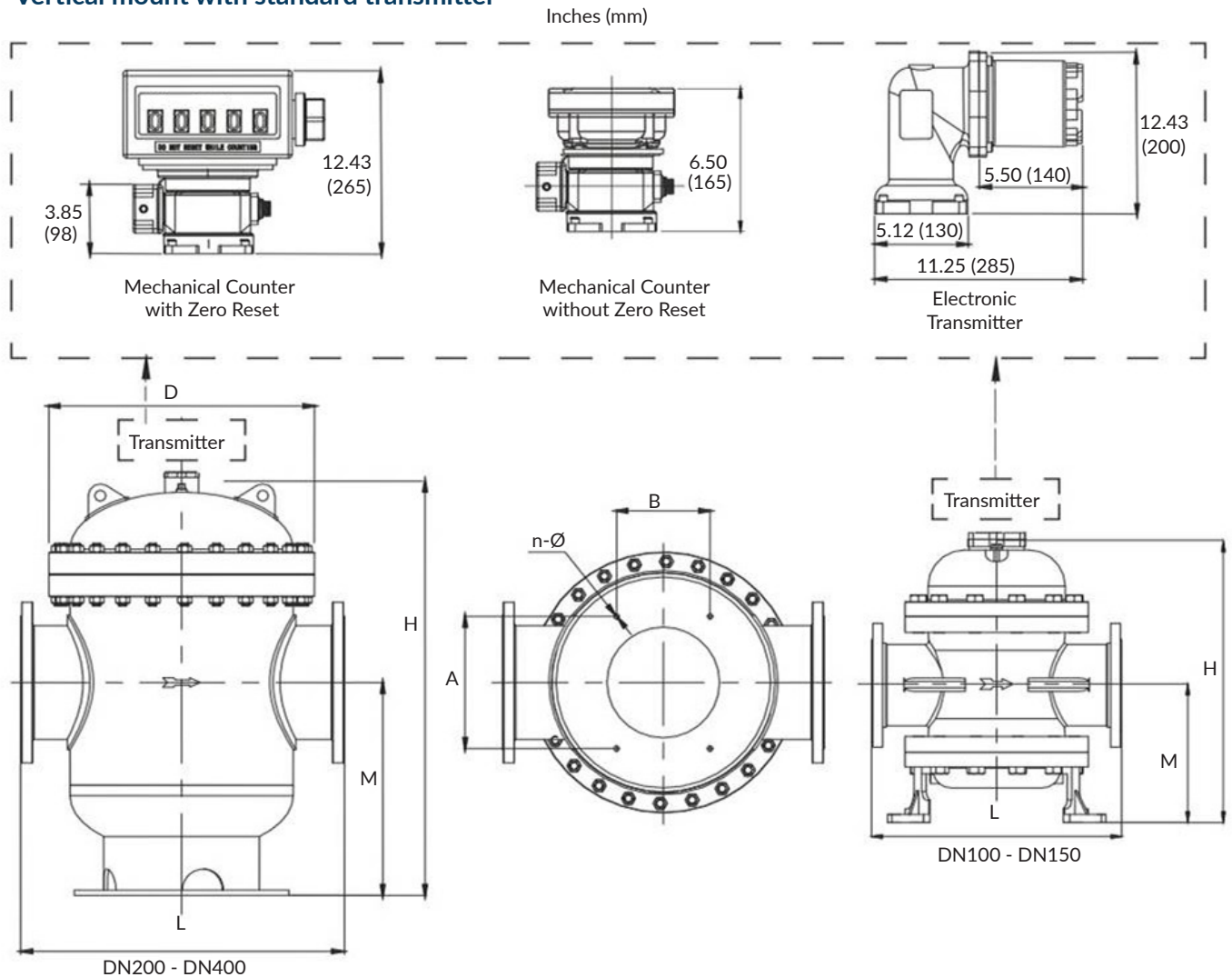

Nominal Size Inches (mm)	Flange to Flange Inches (mm) L	Height Inches (mm) H	Center Inches (mm) M	Body Diameter Inches (mm) D	Installation Dimension A x B	Bolt Dimension n-Ø	Weight lb (kg)
1 1/2" (DN40)	9.8" (250)	13.2" (335)	5.0" (126)	7.3" (185)			88 (40)
2" (DN50)	14.2" (360)	16.1" (410)	8.7" (150)	9.3" (235)			132 (60)
3" (DN80)	15.7" (400)	21.1" (535)	8.7" (222)	12.0" (305)			253 (115)
4" (DN100)	17.7" (450)	22.8" (580)	10.6" (270)	12.8" (325)	13.4" x 8.5" (340 x 215)	4 - Ø 0.9 (23)	330 (150)
6" (DN150)	22.0" (560)	26.6" (675)	12.5" (318)	16.3" (415)	17.7" x 9.4" (450 x 240)	4 - Ø 0.9 (23)	705 (320)
8" (DN200)	27.6" (700)	37.2" (945)	17.7" (450)	20.9" (530)	17.9" x 7.8" (445 x 200)	4 - Ø 0.9 (23)	1234 (560)
10" (DN250)	39.4" (1000)	40.5" (1029)	19.7" (500)	24.4" (620)	20.6" x 9.8" (524 x 250)	4 - Ø 0.9 (25)	2204 (1000)
12" (DN300)	39.4" (1000)	51.0" (1295)	25.2" (640)	30.7" (780)	25.4" x 11.8" (645 x 300)	4 - Ø 0.9 (25)	3218 (1460)
16" (DN400)	47.2" (1200)	62.4" (1584)	28.3" (750)	38.6" (980)	27.6" Ø700	6 - Ø 1.0 (25)	4409 (2000)

- \* NOTE: 1. Please consult factory for other requirements  
 2. Consult factory for oversize / undersize flange connection.  
 3. Refer to Figure 1 and Figure 2, the heating jacket (figure 3) should be added for working temperatures of 80 ~ 150°C without adapter. For working temperatures of 150 ~ 250°C, the heating jacket should be added with adapter.

## ■ Horizontal mount with standard transmitter

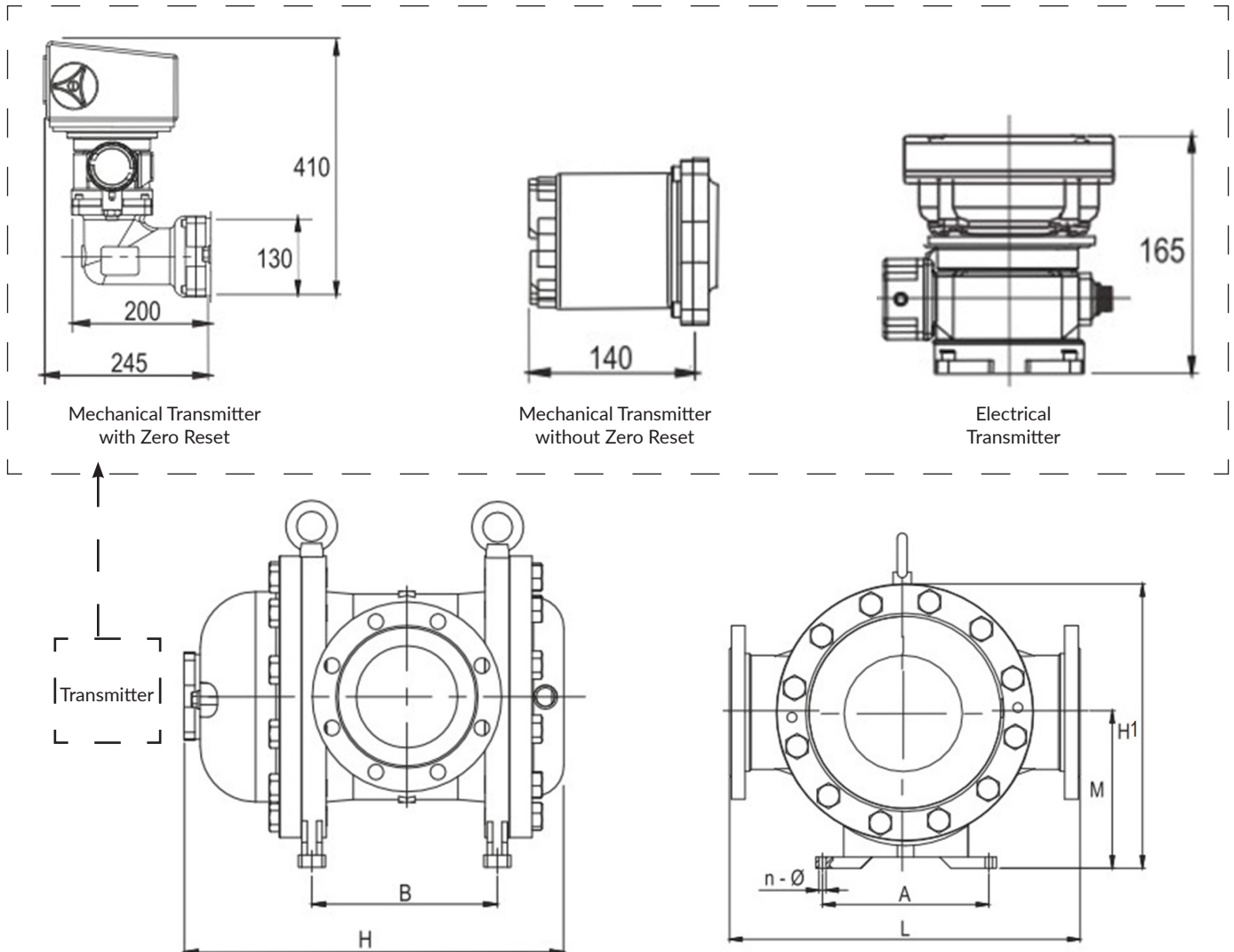

DN in (mm)	Flange to Flange inches (mm) L	Total Height in (mm) H	Height in (mm) H1	Center in (mm) M	Body Diam- eter in (mm) D	Installation Dimension A x B	Bolt Dimension n-Ø	Weight lb (kg)
1½" (DN40)	9.8" (250)	12.2" (335)	7.3" (185)	3.7" (95)	7.3" (185)			88 (40)
2" (DN50)	14.2" (360)	16.1" (410)	9.3" (235)	4.7" (120)	9.3" (235)			132 (60)
3" (DN80)	15.7" (400)	21.1" (535)	12.0" (306)	7.9" (200)	12.0" (305)			253 (115)
4" (DN100)	17.7" (450)	20.3" (515)	14.8" (375)	8.3" (210)	12.8" (325)	9.8"x 8.7" (250 x 220)	4 - 0.82 (Ø20)	330 (150)
6" (DN150)	22.0" (560)	23.0" (585)	18.3" (465)	10.0" (255)	16.3" (415)	9.8" x 10.0" (250 x 270)	4 - 0.82 (Ø20)	695 (315)

\* NOTE: 1. Please consult factory for other requirements

2. Consult factory for oversize / undersize flange connection.

3. Refer to Figure 1 and Figure 2 , the heating jacket (figure 3) should be added for working temperature of 80 ~ 150°C without adapter. For working temperatures of 150 ~ 250°C, the heating jacket should be added with adapter.

- Heat Sink, sizes 1½" (40mm) for high temperature options; installed between head and transmitter

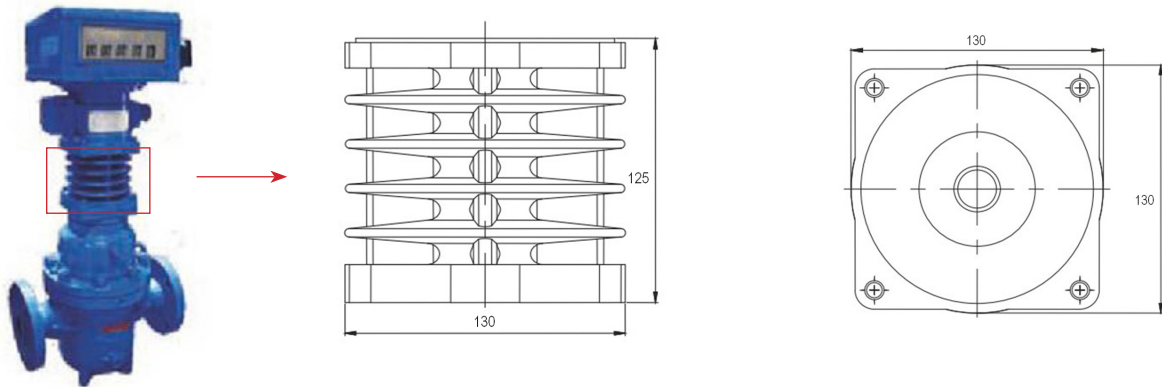

- \* NOTE: 1. Please consult factory for other requirements  
 2. Consult factory for oversize / undersize flange connection.  
 3. Refer to Figure 1 and Figure 2 , the heating jacket (figure 3) should be added for working temperatures of 80 ~ 150°C without adapter. For working temperatures 150 ~ 250°C, the heating jacket should be added with adapter.

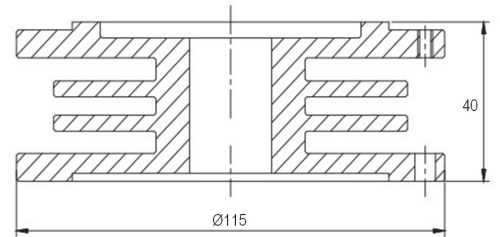

- Mechanical Transmitter without Zero Reset

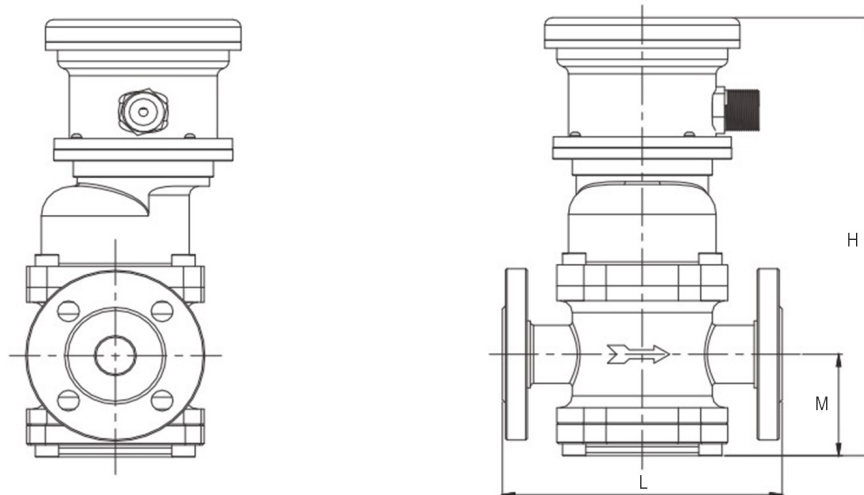

- \* NOTE: 1. Please consult factory for other requirements  
 2. Consult factory for oversize / undersize flange connection.  
 3. The heating jacket should be added with the working temperature of 80-150°C without diverter. For working temperatures of 150 ~ 250°C, heating jacket should be added with adapter.

### ■ Smart type Ex approved transmitters



- Explosion proof according ATEX, IECEx and CSA/C-US.
- 7 digit flow rate and 11 digit accumulated total.
- 16 point linearization of the flow curve - with interpolation.
- High and low flow rate alarm monitoring.
- Clear flashing LED backlight in case of an alarm.
- Power options: Loop powered, battery and 9 - 27V<sub>DC</sub>.
- Integrated HART 7 communication protocol.
- Isolated, loop powered 4 - 20mA output according to linearized flow rate.
- Four configurable digital outputs for high and low flow rate alarms or scaled pulse retransmission of the linearized accumulated total.

### ■ FAST Strainer



Nominal Diameter (mm)	½, 1, 1½, 2, 3, 4, 6, 8, 10, 12 (15, 25, 40, 50, 80, 100, 150, 200, 250, 300)
Nominal Pressure:	232, 362, 580, 928 psi (16, 25, 40, 64 Bar)
Mesh Size:	40 (Standard)
Fluid Temperature:	-20°C ~ +80°C, -20°C ~ +120°C, -20°C ~ +150°C, -20°C ~ +250°C

Strainer is installed upstream of the flowmeter to filter the solid impurities in the fluid to prevent blockage and enhance meter performance.

NOTE: The mesh size can be custom made to the customer's requirements.

## ALPDFT STRAINER



The ALPDFT Series Filter can eliminate the impurities and contaminants from the liquid so that normal operation of the flowmeter can be ensured and service life of the flowmeter can be prolonged.

### Model Selection Guide

ALPDFT-	**_	**_	**_	**_	DESCRIPTION
½ ~12" (DN15~DN300)	**				Internal Dia.
Carbon Steel		G			Material
SS #304		304			
SS #316		316			
232 psi (1.6 Mpa)			1.6		Pressure
302 psi (2.5 Mpa)			2.5		
580 psi (4.0 Mpa)			4.0		
928 psi (6.4 Mpa)			6.4		
Other pressure			OP		

## ALPDGE GAS ELIMINATOR

Presence of gas bubbles in the fluid contributes to measuring errors. Installing the Gas Eliminator before the flowmeter can eliminate and discharge entrained gas in the liquid.

### Model Selection Guide

ALPDGE-	**_	**_	**_	**_	DESCRIPTION
½ ~12" (DN15~DN300)	**				Internal Dia.
Carbon Steel		G			Material
SS #304		304			
SS #316		316			
232 psi (1.6 Mpa)			1.6		Pressure
302 psi (2.5 Mpa)			2.5		
580 psi (4.0 Mpa)			4.0		
928 psi (6.4 Mpa)			6.4		
Other pressure			OP		



## ALPDFE STRAINER AND GAS ELIMINATOR



The ALPDFE is an integrated Strainer and Gas Eliminator. It can filter solid impurities and expel gas in the liquid at the same time.

### Model Selection Guide

ALPDFE-	**_	**_	**_	**_	DESCRIPTION
½ ~32" (DN40~DN800)	**				Internal Dia.
Carbon Steel		G			Material
SS #304		304			
SS #316		316			
232 psi (1.6 Mpa)			1.6		Pressure
302 psi (2.5 Mpa)			2.5		
580 psi (4.0 Mpa)			4.0		
928 psi (6.4 Mpa)			6.4		
Other pressure			OP		

\*\* Please contact your local SmartMeasurement application engineer  
You also need to provide the following information:

<b>TYPE OF FLUID</b>	Please provide the name of your fluid, including operating density and viscosity
<b>LINE SIZE</b>	Nominal pipe size and sensor connection type (insertion, clamp, etc..)
<b>PROCESS PRESSURE AND TEMPERATURE</b>	We will calibrate your flowmeter as close to your operating conditions as possible
<b>TYPE OF ELECTRONICS</b>	Output and installation type (compact, wall mount, etc..)
<b>FLOW RANGE</b>	Please provide the flow range

ALBRPD-	**_	**_	**_	**_	**_	**_	**_	**_	**_	DESCRIPTION
0.1% Of reading	1									Accuracy
0.2% Of reading	2									
0.5% Of reading	5									
¼" ~ 16" (DN8~DN400)		**								Internal Dia.
Electronic counter (24 Vdc and 4-20mA)			D							Transmitter style
Electronic counter (AC power and 4-20mA)			M							
Electronic counter (Battery power)			T							
Standard mechanical counter			J							
Smith mechanical counter with zero reset			M3							
232 psi (1.6 Mpa)				1.6						Pressure
362 psi (2.5 Mpa)				2.5						
580 psi (4.0 Mpa)				4.0						
928 psi (6.4 Mpa)				6.4						
Casing & rotator are cast. steel					G					Rotar & casing material
Casing is CS and Rotator is SS# 304					S304					
Casing is CS and Rotator is SS# 316					S316					
Casing & rotator are SS# 304					SS304					
Casing & rotator are SS# 316					SS316					
Working temperature: -4 ~ 176°F (-20°C ~ +80°C)						A				Temperature
Working temperature up to 300°F (+150°C)						B				
Working temperature up to 176°F (+250°C)						C				
None options							NN			Option
RS485/Modbus/data logger - for Electronic counter							485			
CSA Approved Class 1 Div 1 - for Electronic counter							CSA			
ATEX Approved Class 1 Div 1 - for Electronic counter							ATEX			
Extra Analog output for mechanical counters - Pulse							FP			
Extra Analog output for mechanical counters - 4-20mA							FI			
Special fluid: gasoline or liquified gas							SF			
Warmer jacket for heat preservation (steam or oil)							HJ			
Filter								ALPDFT		Accessories
Air eliminator								ALPDGE		
Filter and gas eliminator								ALPDFTG		

